

# HALE TYPE CSD PUMP

SINGLE - STAGE FRONT MOUNT PUMP

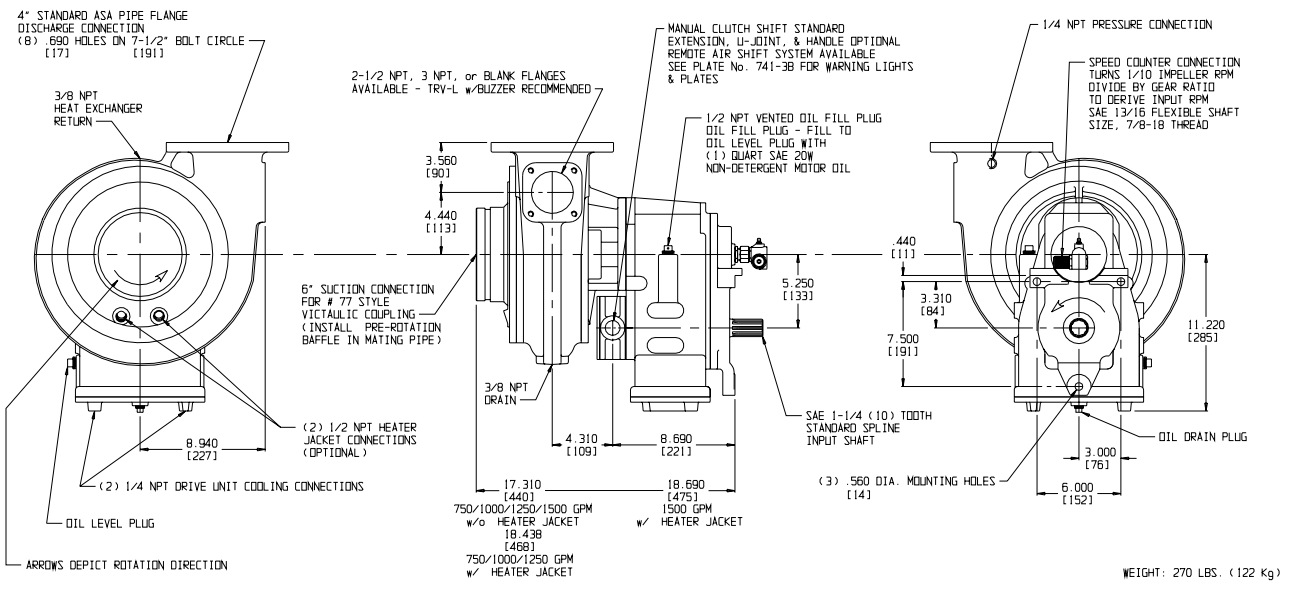

## MODEL CSD - VERTICAL TRANSMISSION STANDARD

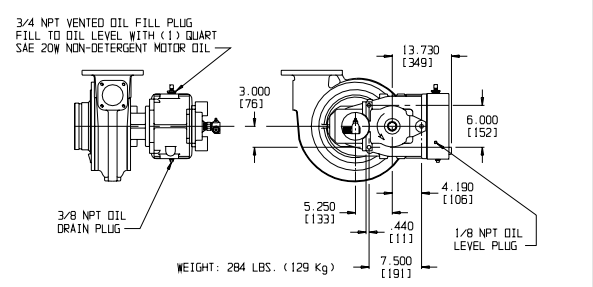
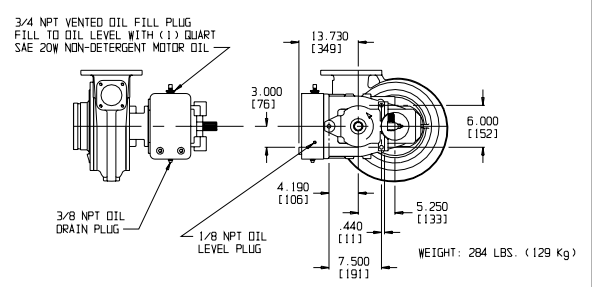

## MODEL CSD - HORIZONTAL RIGHT TRANSMISSION OPTIONAL HORIZONTAL LEFT TRANSMISSION OPTIONAL

| MODEL | RATING | GPM  | RATIO  |
|-------|--------|------|--------|
| CSD*  | 750    | 1000 | 125037 |
| CSD*  | 750    | 1000 | 125016 |
| CSD*  | 750    | 1000 | 125097 |
| CSD*  | 750    | 1000 | 125081 |
| CSD*  | 750    | 1000 | 125059 |
| CSD*  | 750    | 1000 | 125040 |

\* ADD RATING CODE FOR PUMP MODEL  
 75 = 750 GPM 100 = 1000 GPM 125 = 1250 GPM 150 = 1500 GPM

**WARNING!**  
 EXCEEDING THESE LIMITS OR FAILURE TO FOLLOW THE RECOMMENDATIONS OUTLINED ON THIS DRAWING COULD DAMAGE THE PUMP AND RESULT IN PERSONAL INJURY.  
 MAX PUMP PRESSURE: DYNAMIC = 400 PSIG (28 BAR), STATIC = 600 PSIG (41 BAR)  
 MAXIMUM POWER INPUT FOR PUMPING = 300 HP (225 KW)  
 MAXIMUM INPUT RPM: 2200 2410 2880 3280 3720  
 PUMP RATIO: 2.37 2.16 1.81 1.59 1.40  
 PUMPING OPERATIONS IMPOSE A TORQUE LOAD ON THE PUMP INPUT SHAFT AND RELATED EQUIPMENT WHICH DRIVES THE PUMP. AFTER ESTABLISHING MAXIMUM TORQUE LOADS, SUBMIT THE DATA TO THE ENGINE AND DRIVELINE MANUFACTURERS FOR THEIR RECOMMENDATION AND APPROVAL OF THE APPLICATION. ADDITIONALLY, IT MAY BE NECESSARY TO INSTALL A DAMPING DEVICE BETWEEN THE ENGINE AND PUMP TO ABSORB AND SUPPRESS THE TORSIONAL VIBRATION INHERENT IN SOME DIESEL ENGINES.

**NOTES**

- 1) TO CONFORM TO NFPA 1901, APPARATUS MANUFACTURER MUST INSTALL (4) SHIFT AND THROTTLE CONTROL WARNING LIGHTS. THE INDICATOR LIGHTS ARE FURNISHED WITH PUMP. SEE PLATE NO. 741-3B.
- 2) THIS PRODUCT AND ITS COMPONENTS ARE PROTECTED BY ONE OR MORE OF THE FOLLOWING U.S. PATENTS AND OTHER PATENTS PENDING:  
 3918681, 4089345, 4311440, 4653978.
- 3) DIMENSIONS ARE IN INCHES AND ( MILLIMETERS ).

PLATE NO. 896AB

|         |     |                     |    |         |      |
|---------|-----|---------------------|----|---------|------|
| 1988-46 | B   | CORRECTED DIMENSION | CK | 6-24-98 | MS   |
| 1988-29 | A   | REDRAWN ON CAD      | CK | 4-21-98 | MS   |
| ECD NO  | REV | CHANGED FROM        | BY | DATE    | APVD |

**HALE** HALE PRODUCTS, INC.  
 A Unit of IDEXX Corporation  
 Conshohocken, PA 19342 USA

SCALE: HALF